

ESP32/ESP8266 Projets en cours

ESP 32/ESP8266 station meteo

[projet-station-meteo-interface-html-esp8266-dht22-bmp180 partie 1 FR](#)

[esp8266-web-serveur-partie2-interaction-arduino-interface-html FR](#)

ESP8266 Marc

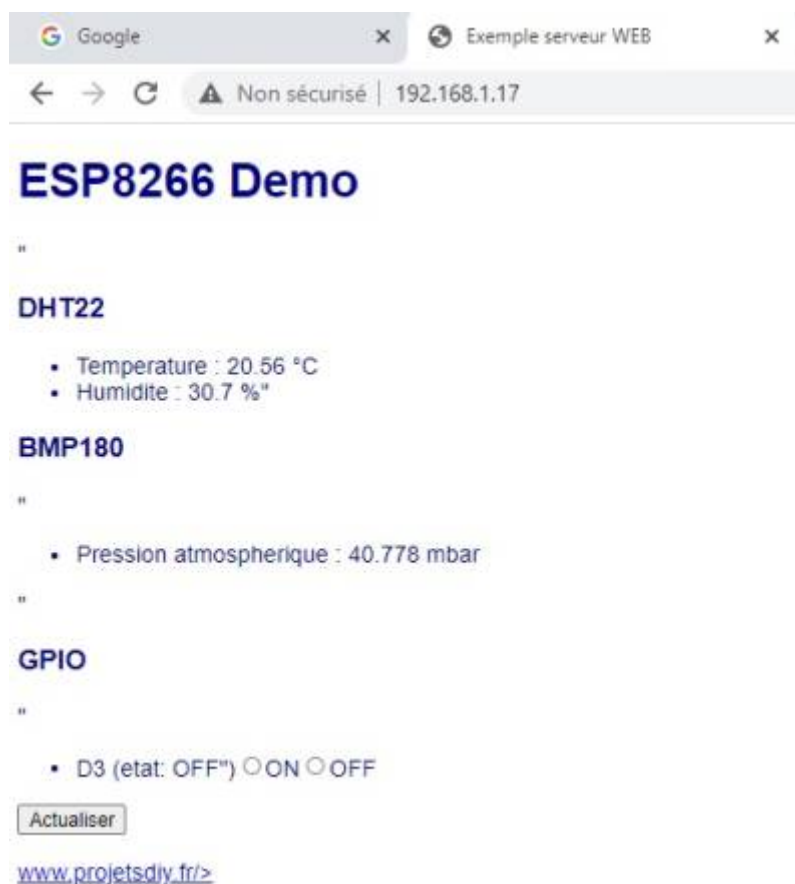

Exemple_Serveur_Web1.ino

```
// Essais de programmation de sites Internet avec ESP8266
// M. Sabarthes le 8 janvier 2022
// BON COURAGE !!

#include "Arduino.h"
#include "ESP8266WiFi.h"
// #include "InfoConnexion.h"
#include "ESP8266WebServer.h"

// Définition des entrées/sorties de l'ESP8266
```

```
#define PIN_D0 16
#define PIN_D1 5 // ==> Envoi un signal PWM au démarrage
!!
#define PIN_D2 4
#define PIN_D3_VERTE 0 // LED VERTE ATTENTION ==> Envoi un
signal PWM au démarrage !!
#define PIN_D4_ESP 2 // Led Blue du circuit
#define PIN_D5_ROUGE 14 // LED ROUGE ==> Envoi un signal PWM au
démarrage !!
#define PIN_D6_BP 12 // BOUTON POUSSOIR
#define PIN_D7_INTER 13 // INTERRUPTEUR
#define PIN_D8 15 // ==> Envoi un signal PWM au démarrage
!!
#define PIN_D9 3 // Objet : Serial RX ==> Prend l'état
HIGH au démarrage !!
#define PIN_D10 1 // Objet : Serial TX
#define PIN_A0 // Analog 10 bits : maxi 1 volt !!

#define ssid "Votre LiveBox" // WiFi SSID
#define password "Le mot de passe" // WiFi password
// #define DHTTYPE DHT22 // DHT type (DHT11, DHT22)
// #define DHTPIN D4 // Broche du DHT / DHT Pin
// #define LEDPIN D3 // Led

float t = 0.0 ;
float h = 0.0 ;
float p = 0.0;
//String etatLed = "OFF";
char etatLed[] = "OFF";
// Prototype des fonctions
void handleSubmit();

// =====
// DEBUT CODE HTML =
// =====
const char page[] PROGMEM = R"=====(
<!doctype html>
<html lang="fr">
  <head>
    <meta charset="utf-8">
    <title>Exemple serveur WEB</title>
    <meta http-equiv='refresh' content='10' />
  <style>
    body
    {
      background-color: #ffffff;
      font-family: Arial, Helvetica, Sans-Serif;
      Color: #000088;
    }

```

```

        </style>
    </head>
    <body>
    <h1>ESP8266 Demo</h1>"
    <h3>DHT22</h3>
    <ul>
        <li>Temperature : %0.2f °C</li>
        <li>Humidite : %0.1f %%"</li>
    </ul>
    <h3>BMP180</h3>"
    <ul>
        <li>Pression atmospherique : %0.3f mbar</li>
    </ul>"
    <h3>GPIO</h3>
    <form action='/' method='POST'>"
        <ul>
            <li>D3 (etat: %s"<INPUT type='radio' name='LED'
value='1'>ON<INPUT type='radio' name='LED' value='0'>OFF</li>
        </ul>
        <INPUT type='submit' value='Actualiser'>
        <p>
            <a href='http://www.projetsdiy.fr'>www.projetsdiy.fr/</a>
        </p>
    </body>
</html>)<=====";
// =====
// = FIN CODE HTML =
// =====

// Création des objets / create Objects
ESP8266WebServer server ( 80 );
/*
Tout le code HTML reste une simple chaîne de caractère facile à
manipuler. Vous avez du voir
dans le texte qu'il y a des %s %0.1d et %u. Ce sont les emplacements
des données que l'on va
actualiser à chaque fois que la page change.
Pour mettre à jour la page, il suffit de remplacer chaque variable par
sa valeur, voici comment faire:
On détermine la taille de la page (le nombre de caractères). par
sécurité, vous pouvez ajouter
quelques caractères supplémentaires.
*/
//int pagesize = sizeof(page) + 10;
// On prépare un buffer qui contiendra la page modifiée
//char newpage[pagesize] = "";
/*
Maintenant, il suffit de substituer chaque variable par sa valeur à
l'aide de la méthode sprintf
en utilisant le format indiqué. Par exemple %s pour une chaîne, %0.1d
pour un nombre décimal avec

```

```
un chiffre derrière la virgule...
*/
// Fonction getpage: mise à jour du contenu de la page HTML
String getPage()
{
  // Préparation de la page Internet
  char newpage[(sizeof(page) + 10)] = "";
  sprintf(newpage, page, t, h, p, etatLed);
  //sprintf(newpage, page, 11, 22, 33, etatLed);
  return newpage;
}
// Mise à jour de la page WEB
void handleRoot(){
  if (server.hasArg("LED"))
  {
    handleSubmit();
  }
  else
  {
    server.send ( 200, "text/html", getPage() );
  }
}

void handleSubmit()
{
  // Actualise le GPIO / Update GPIO
  String LEDValue;
  LEDValue = server.arg("LED");
  Serial.println("Set GPIO ");
  Serial.print(LEDValue);
  if ( LEDValue == "1" ) {
    digitalWrite(PIN_D3_VERTE, 1);
    strcat(etatLed,"On");
    server.send ( 200, "text/html", getPage() );
  } else if ( LEDValue == "0" ) {
    digitalWrite(PIN_D3_VERTE, 0);
    strcat(etatLed,"Off");
    server.send ( 200, "text/html", getPage() );
  } else {
    Serial.println("Err Led Value");
  }
}

void setup() {
  Serial.begin (9600);
  Serial.println("Démarrage !!");
  pinMode(PIN_D3_VERTE,OUTPUT);
  pinMode(PIN_D4_ESP,OUTPUT);
  // Initialisation du BMP180 / Init BMP180
```

```
/*
  if ( !bmp.begin() ) {
    Serial.println("BMP180 KO!");
    while(1);
  } else {
    Serial.println("BMP180 OK");
  }
*/
WiFi.begin (ssid,password);
// Attente de la connexion au réseau WiFi / Wait for connection
while (WiFi.status() != WL_CONNECTED)
{
  delay ( 500 ); Serial.print ( "." );
}
// Connexion WiFi établie / WiFi connexion is OK
Serial.println ("" );
Serial.print ("Connected to "); Serial.println (ssid );
Serial.print ("IP address: "); Serial.println (WiFi.localIP());
digitalWrite(PIN_D4_ESP,LOW);          // Allumer LED Blue de
l'ESP8266

// On branche la fonction qui gère la première page / link to the
function that manage launch page
server.on ("/",handleRoot);

server.begin();
Serial.println ("HTTP server started");
}

void loop()
{
  server.handleClient();
/*
  t = dht.readTemperature();
  h = dht.readHumidity();
  p = bmp.readPressure() / 100.0F;
*/
  t=20.5555;
  h=30.6666;
  p=40.7777;
  delay(1000);
}
```

ESP32 commande chauffage

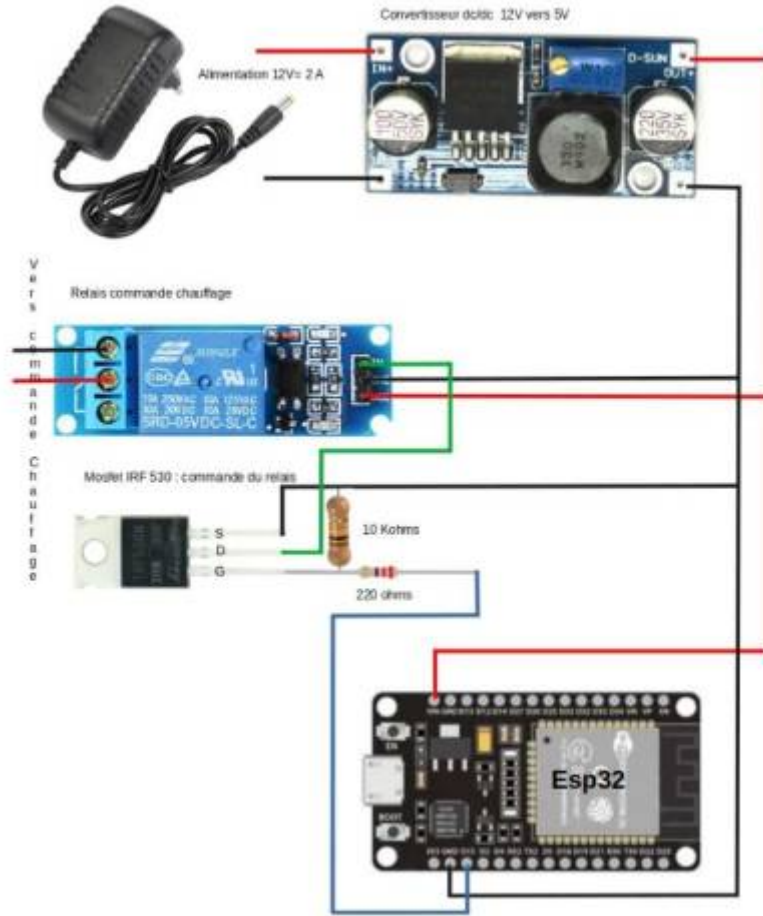

Apercu de la page web via <http://192.168.1.xx>

ESP Web Server

Relay #1 - GPIO 15



**** version 1 ****

[ESP32 relais_OTA_001_Main.ino](#)

```
/*  
Rui Santos
```

Complete project details at
<https://RandomNerdTutorials.com/esp32-relay-module-ac-web-server/>

The above copyright notice and this permission notice shall be included in all copies or substantial portions of the Software.
*****/

```
// Import required libraries
#include "WiFi.h"
#include "ESPAsyncWebServer.h"
#include <ESPmDNS.h>
#include <WiFiUdp.h>
#include <ArduinoOTA.h>

// Set to true to define Relay as Normally Open (NO)
#define RELAY_NO    false

// Set number of relays
#define NUM_RELAYS  1

// Assign each GPIO to a relay
int relayGPIOs[NUM_RELAYS] = {15};

// Replace with your network credentials
const char* ssid = "Livebox-7D70";
const char* password = "chanterie19282008";

/*
// Wifi castellab
const char* ssid = "castellab";
const char* password = "Castel37110$";
*/

void Wifi_connected(WiFiEvent_t event, WiFiEventInfo_t info){
  Serial.println("Successfully connected to Access Point");
}

void Get_IPAddress(WiFiEvent_t event, WiFiEventInfo_t info){
  Serial.println("WIFI is connected!");
  Serial.println("IP address: ");
  Serial.println(WiFi.localIP());
}

void Wifi_disconnected(WiFiEvent_t event, WiFiEventInfo_t info){
  Serial.println("Disconnected from WIFI access point");
  Serial.print("WiFi lost connection. Reason: ");
  Serial.println(info.disconnected.reason);
  Serial.println("Reconnecting...");
  WiFi.begin(ssid, password);
}
```

```
}

const char* PARAM_INPUT_1 = "relay";
const char* PARAM_INPUT_2 = "state";

// Create AsyncWebServer object on port 80
AsyncWebServer server(80);

const char index_html[] PROGMEM = R"rawliteral(
<!DOCTYPE HTML><html>
<head>
  <meta name="viewport" content="width=device-width, initial-scale=1">
  <style>
    html {font-family: Arial; display: inline-block; text-align:
center;}
    h2 {font-size: 3.0rem;}
    p {font-size: 3.0rem;}
    body {max-width: 600px; margin:0px auto; padding-bottom: 25px;}
    .switch {position: relative; display: inline-block; width: 120px;
height: 68px}
    .switch input {display: none}
    .slider {position: absolute; top: 0; left: 0; right: 0; bottom: 0;
background-color: #ccc; border-radius: 34px}
    .slider:before {position: absolute; content: ""; height: 52px;
width: 52px; left: 8px; bottom: 8px; background-color: #fff; -webkit-
transition: .4s; transition: .4s; border-radius: 68px}
    input:checked+.slider {background-color: #2196F3}
    input:checked+.slider:before {-webkit-transform: translateX(52px);
-ms-transform: translateX(52px); transform: translateX(52px)}
  </style>
</head>
<body>
  <h2> Castellab commande chauffage</h2>
  %BUTTONPLACEHOLDER%
<script>function toggleCheckbox(element) {
  var xhr = new XMLHttpRequest();
  if(element.checked){ xhr.open("GET",
"/update?relay="+element.id+"&state=1", true); }
  else { xhr.open("GET", "/update?relay="+element.id+"&state=0", true); }
}
  xhr.send();
}</script>
</body>
</html>
)rawliteral";

// Replaces placeholder with button section in your web page
String processor(const String& var){
```



```

//Serial.println(var);
if(var == "BUTTONPLACEHOLDER"){
  String buttons = "";
  for(int i=1; i<=NUM_RELAYS; i++){
    String relayStateValue = relayState(i-1);
    buttons+= "<h4>Relay #" + String(i) + " - GPIO " +
relayGPIOs[i-1] + "</h4><label class=\"switch\"><input
type=\"checkbox\" onchange=\"toggleCheckbox(this)\" id=\"" + String(i)
+ "\" " + relayStateValue + "><span class=\"slider\"></span></label>";
  }
  return buttons;
}
return String();
}

String relayState(int numRelay){
  if(RELAY_NO){
    if(digitalRead(relayGPIOs[numRelay-1])){
      return "";
    }
    else {
      return "checked";
    }
  }
  else {
    if(digitalRead(relayGPIOs[numRelay-1])){
      return "checked";
    }
    else {
      return "";
    }
  }
  return "";
}

void setup(){
  // Serial port for debugging purposes
  Serial.begin(115200);
  Serial.println("Booting");
  pinMode(relayGPIOs[0], OUTPUT);
  digitalWrite(relayGPIOs[0],LOW);
  if(RELAY_NO){
    digitalWrite(relayGPIOs[0], LOW);
  }
  else{
    digitalWrite(relayGPIOs[0], HIGH);
  }

  // Set all relays to off when the program starts - if set to Normally
  Open (NO), the relay is off when you set the relay to HIGH

```

```
/*for(int i=1; i<=NUM_RELAYS; i++){
  pinMode(relayGPIOs[i-1], OUTPUT);
  if(RELAY_NO){
    digitalWrite(relayGPIOs[i-1], LOW);
  }
  else{
    digitalWrite(relayGPIOs[i-1], HIGH);
  }
}
*/

// Connect to Wi-Fi
WiFi.mode(WIFI_STA);

WiFi.disconnect(true);
delay(1000);

WiFi.onEvent(Wifi_connected, SYSTEM_EVENT_STA_CONNECTED);
WiFi.onEvent(Get_IPAddress, SYSTEM_EVENT_STA_GOT_IP);
WiFi.onEvent(Wifi_disconnected, SYSTEM_EVENT_STA_DISCONNECTED);
WiFi.begin(ssid, password);
Serial.println("Waiting for WIFI network...");

/*
  WiFi.begin(ssid, password);
  while (WiFi.waitForConnectResult() != WL_CONNECTED) {
    Serial.println("Connection Failed! Rebooting...");
    delay(5000);
    ESP.restart();
  }
*/
/*
  while (WiFi.status() != WL_CONNECTED) {
    delay(1000);
    Serial.println("Connecting to WiFi..");
  }
*/

// Route for root / web page
server.on("/", HTTP_GET, [](AsyncWebServerRequest *request){
  request->send_P(200, "text/html", index_html, processor);
});

// Send a GET request to
<ESP_IP>/update?relay=<inputMessage>&state=<inputMessage2>
server.on("/update", HTTP_GET, [] (AsyncWebServerRequest *request) {
```

```

String inputMessage;
String inputParam;
String inputMessage2;
String inputParam2;
// GET input1 value on <ESP_IP>/update?relay=<inputMessage>
if (request->hasParam(PARAM_INPUT_1) &
request->hasParam(PARAM_INPUT_2)) {
    inputMessage = request->getParam(PARAM_INPUT_1)->value();
    inputParam = PARAM_INPUT_1;
    inputMessage2 = request->getParam(PARAM_INPUT_2)->value();
    inputParam2 = PARAM_INPUT_2;
    if(RELAY_NO){
        Serial.print("NO ");
        digitalWrite(relayGPIOs[inputMessage.toInt()-1],
!inputMessage2.toInt());
    }
    else{
        Serial.print("NC ");
        digitalWrite(relayGPIOs[inputMessage.toInt()-1],
inputMessage2.toInt());
    }
}
else {
    inputMessage = "No message sent";
    inputParam = "none";
}
Serial.println(inputMessage + inputMessage2);
request->send(200, "text/plain", "OK");
});
// Start server
server.begin();

ArduinoOTA
.onStart([]() {
    String type;
    if (ArduinoOTA.getCommand() == U_FLASH)
        type = "sketch";
    else // U_SPIFFS
        type = "filesystem";

    // NOTE: if updating SPIFFS this would be the place to unmount
SPIFFS using SPIFFS.end()
    Serial.println("Start updating " + type);
})
.onEnd([]() {
    Serial.println("\nEnd");
})
.onProgress([](unsigned int progress, unsigned int total) {
    Serial.printf("Progress: %u%%\r", (progress / (total / 100)));
})
.onError([](ota_error_t error) {

```

```
Serial.printf("Error[%u]: ", error);
if (error == OTA_AUTH_ERROR) Serial.println("Auth Failed");
else if (error == OTA_BEGIN_ERROR) Serial.println("Begin
Failed");
else if (error == OTA_CONNECT_ERROR) Serial.println("Connect
Failed");
else if (error == OTA_RECEIVE_ERROR) Serial.println("Receive
Failed");
else if (error == OTA_END_ERROR) Serial.println("End Failed");
});

ArduinoOTA.begin();

/*
  Serial.println("Ready");
  Serial.print("IP address: ");
  Serial.println(WiFi.localIP());
*/

}

void loop() {
  ArduinoOTA.handle();
  delay(1000);
}
```

****version 2 :Inserer les 4 programmes suivant dans le même repertoire****

[ESP32_Relais_OTA_002_Main.ino](#)

```
/*
*****
  Rui Santos
  Complete project details at
  https://RandomNerdTutorials.com/esp32-relay-module-ac-web-server/

  The above copyright notice and this permission notice shall be
  included in all
  copies or substantial portions of the Software.

  Modification GL 01/2022
*****/

// Import required libraries
#include "WiFi.h"
#include "ESPAsyncWebServer.h"
#include <ESPmDNS.h>
```

```
#include <WiFiUdp.h>
#include <ArduinoOTA.h>

#include "configT.h"

// Create AsyncWebServer object on port 80
AsyncWebServer server(80);

#include "page_web001.h"

// Replaces placeholder with button section in your web page
String processor(const String& var){
  //Serial.println(var);
  if(var == "BUTTONPLACEHOLDER"){
    String buttons = "";
    for(int i=1; i<=NUM_RELAYS; i++){
      String relayStateValue = relayState(i);
      buttons+= "<h4>Relay #" + String(i) + " - GPIO " +
relayGPIOs[i-1] + "</h4><label class=\"switch\"><input
type=\"checkbox\" onchange=\"toggleCheckbox(this)\" id=\"" + String(i)
+ "\" " + relayStateValue + "><span class=\"slider\"></span></label>";
    }
    return buttons;
  }
  return String();
}

String relayState(int numRelay){
  if(RELAY_NO){
    if(digitalRead(relayGPIOs[numRelay-1])){
      return "";
    }
    else {
      return "checked";
    }
  }
  else {
    if(digitalRead(relayGPIOs[numRelay-1])){
      return "checked";
    }
    else {
      return "";
    }
  }
  return "";
}

void setup(){
```

```
#include "setup_relais.h"

void loop() {
  ArduinoOTA.handle();
  delay(1000);
}
```

configT.h

```
// Set to true to define Relay as Normally Open (NO)
#define RELAY_NO false

// Set number of relays
#define NUM_RELAYS 1

// Assign each GPIO to a relay
int relayGPIOs[NUM_RELAYS] = {15};

// Replace with your network credentials
const char* ssid = "xxxxxxxxxxxxxxxx";
const char* password = "xxxxxxxxxxxxxxxx";

void Wifi_connected(WiFiEvent_t event, WiFiEventInfo_t info){
  Serial.println("Successfully connected to Access Point");
}

void Get_IPAddress(WiFiEvent_t event, WiFiEventInfo_t info){
  Serial.println("WIFI is connected!");
  Serial.println("IP address: ");
  Serial.println(WiFi.localIP());
}

void Wifi_disconnected(WiFiEvent_t event, WiFiEventInfo_t info){
  Serial.println("Disconnected from WIFI access point");
  Serial.print("WiFi lost connection. Reason: ");
  Serial.println(info.disconnected.reason);
  Serial.println("Reconnecting...");
  WiFi.begin(ssid, password);
}

const char* PARAM_INPUT_1 = "relay";
const char* PARAM_INPUT_2 = "state";
```

page_web001.h

```

const char index_html[] PROGMEM = R"rawliteral(
<!DOCTYPE HTML><html>
<head>
  <meta name="viewport" content="width=device-width, initial-scale=1">
  <style>
    html {font-family: Arial; display: inline-block; text-align:
center;}
    h2 {font-size: 3.0rem;}
    p {font-size: 3.0rem;}
    body {max-width: 600px; margin:0px auto; padding-bottom: 25px;}
    .switch {position: relative; display: inline-block; width: 120px;
height: 68px}
    .switch input {display: none}
    .slider {position: absolute; top: 0; left: 0; right: 0; bottom: 0;
background-color: #ccc; border-radius: 34px}
    .slider:before {position: absolute; content: ""; height: 52px;
width: 52px; left: 8px; bottom: 8px; background-color: #fff; -webkit-
transition: .4s; transition: .4s; border-radius: 68px}
    input:checked+.slider {background-color: #2196F3}
    input:checked+.slider:before {-webkit-transform: translateX(52px);
-ms-transform: translateX(52px); transform: translateX(52px)}
  </style>
</head>
<body>
  <h2>ESP Web Server</h2>
  %BUTTONPLACEHOLDER%
<script>function toggleCheckbox(element) {
  var xhr = new XMLHttpRequest();
  if(element.checked){ xhr.open("GET",
"/update?relay="+element.id+"&state=1", true); }
  else { xhr.open("GET", "/update?relay="+element.id+"&state=0", true);
}
  xhr.send();
}</script>
</body>
</html>
)rawliteral";

```

setup_relais.h

```

// Serial port for debugging purposes
Serial.begin(115200);

// Set all relays to off when the program starts - if set to Normally
Open (NO), the relay is off when you set the relay to HIGH
for(int i=1; i<=NUM_RELAYS; i++){
  pinMode(relayGPIOs[i-1], OUTPUT);
  if(RELAY_NO){
    digitalWrite(relayGPIOs[i-1],LOW);
  }
}

```

```
    else{
        digitalWrite(relayGPIOs[i-1], HIGH);
    }
}
//digitalWrite(relayGPIOs[0], LOW);
// Connect to Wi-Fi
WiFi.begin(ssid, password);
while (WiFi.status() != WL_CONNECTED) {
    delay(1000);
    Serial.println("Connecting to WiFi..");
}

// Print ESP32 Local IP Address
Serial.println(WiFi.localIP());

// Route for root / web page
server.on("/", HTTP_GET, [](AsyncWebServerRequest *request){
    request->send_P(200, "text/html", index_html, processor);
});

// Send a GET request to
<ESP_IP>/update?relay=<inputMessage>&state=<inputMessage2>
server.on("/update", HTTP_GET, [] (AsyncWebServerRequest *request) {
    String inputMessage;
    String inputParam;
    String inputMessage2;
    String inputParam2;
    // GET input1 value on <ESP_IP>/update?relay=<inputMessage>
    if (request->hasParam(PARAM_INPUT_1) &
request->hasParam(PARAM_INPUT_2)) {
        inputMessage = request->getParam(PARAM_INPUT_1)->value();
        inputParam = PARAM_INPUT_1;
        inputMessage2 = request->getParam(PARAM_INPUT_2)->value();
        inputParam2 = PARAM_INPUT_2;
        if(RELAY_NO){
            Serial.print("NO ");
            digitalWrite(relayGPIOs[inputMessage.toInt()-1],
!inputMessage2.toInt());
        }
        else{
            Serial.print("NC ");
            digitalWrite(relayGPIOs[inputMessage.toInt()-1],
inputMessage2.toInt());
        }
    }
    else {
        inputMessage = "No message sent";
        inputParam = "none";
    }
}
```



```
Serial.println(inputMessage + inputMessage2);
request->send(200, "text/plain", "OK");
});

// Start server
server.begin();
// code pour inclure la programmation via le wifi en OTA
ArduinoOTA
.onStart([]() {
  String type;
  if (ArduinoOTA.getCommand() == U_FLASH)
    type = "sketch";
  else // U_SPIFFS
    type = "filesystem";

  // NOTE: if updating SPIFFS this would be the place to unmount
  SPIFFS using SPIFFS.end()
  Serial.println("Start updating " + type);
})
.onEnd([]() {
  Serial.println("\nEnd");
})
.onProgress([](unsigned int progress, unsigned int total) {
  Serial.printf("Progress: %u%%\r", (progress / (total / 100)));
})
.onError([](ota_error_t error) {
  Serial.printf("Error[%u]: ", error);
  if (error == OTA_AUTH_ERROR) Serial.println("Auth Failed");
  else if (error == OTA_BEGIN_ERROR) Serial.println("Begin
Failed");
  else if (error == OTA_CONNECT_ERROR) Serial.println("Connect
Failed");
  else if (error == OTA_RECEIVE_ERROR) Serial.println("Receive
Failed");
  else if (error == OTA_END_ERROR) Serial.println("End Failed");
});

ArduinoOTA.begin();
}
```

From:

<http://chanterie37.fr/fablab37110/> - Castel'Lab le Fablab MJC de Château-Renault

Permanent link:

<http://chanterie37.fr/fablab37110/doku.php?id=start:arduino:esp32:projetsencours&rev=1642601268>

Last update: 2023/01/27 16:08

